

**BACCALAURÉAT PROFESSIONNEL**  
**OUVRAGES DU BÂTIMENT**  
**Aluminium, verre et matériaux de synthèse**

**Session 2010**

**Durée : 3 heures**

**Coefficient : 2**

**EPREUVE E2 (U2) - Préparation et suivi d'une  
fabrication et d'une mise en œuvre sur chantier**

Ce dossier comporte **9** pages, numérotées de **DTC 1 / 9** à **DTC 9 / 9**.  
Assurez-vous que cet exemplaire est complet.  
S'il est incomplet, demandez un autre exemplaire au chef de salle.

# DOCUMENT GAMMISTE PORTE BATTANTE SANS SEUIL OUVERTURE VERS L'INTERIEUR 1 ET 2 VANTAUX

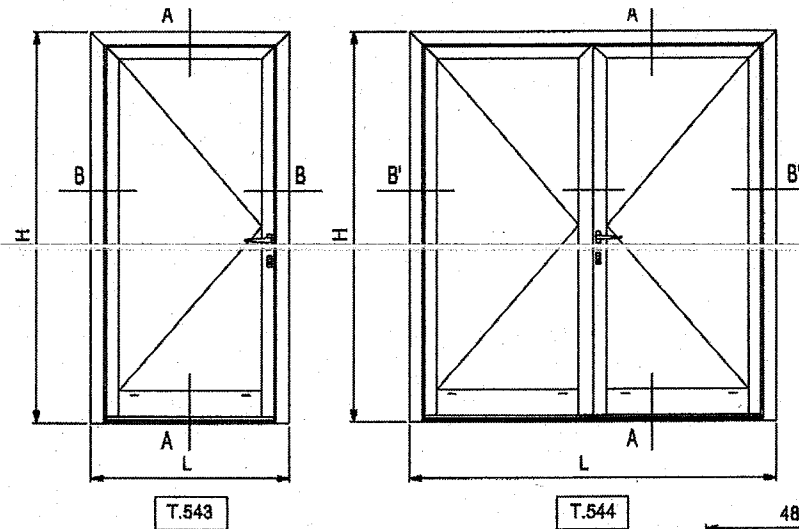

COUPE B Ech. 1/2  
SECTION B Scale 1/2

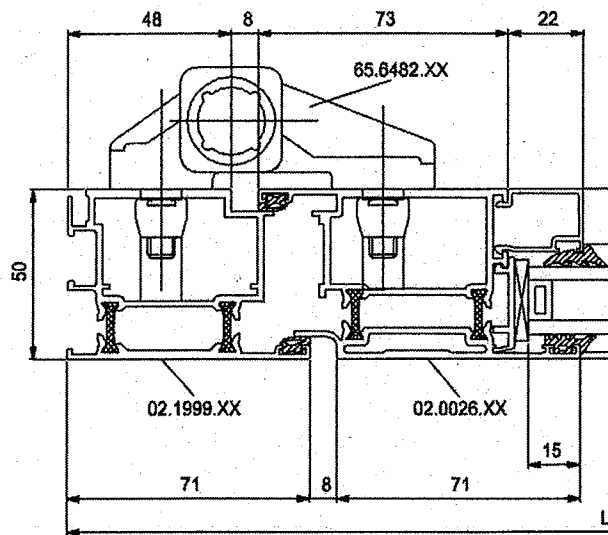

Des noeuds Echelle 1 sont présentés aux  
planches TE. ...

Knot scale 1 have present in  
board TE. ...

COUPE B' Ech. 1/2  
SECTION B' Scale 1/2

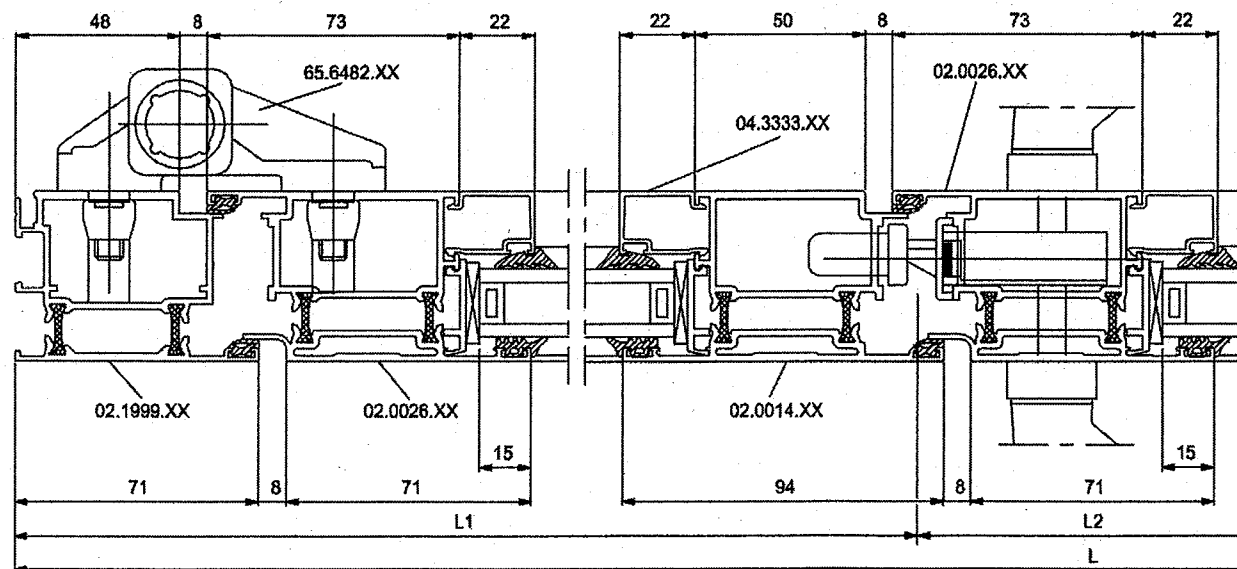

COUPE A Ech. 1/2  
SECTION A Scale 1/2

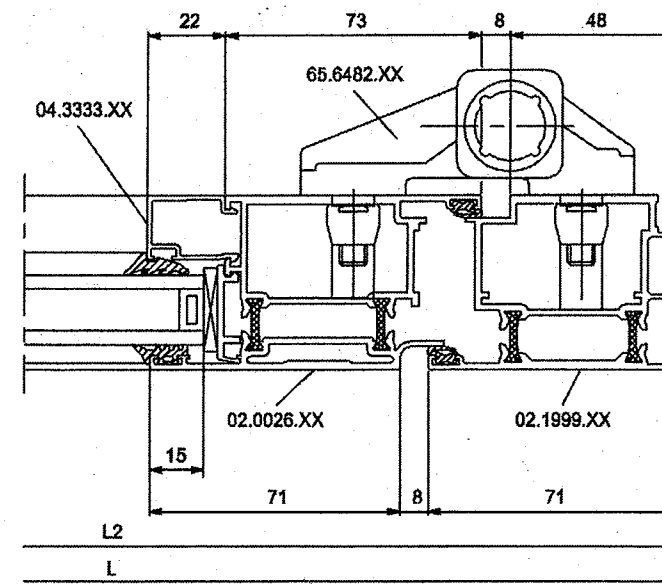
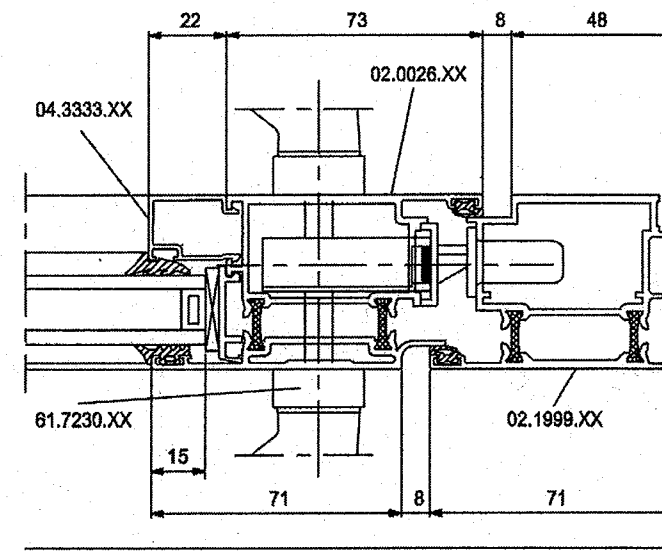
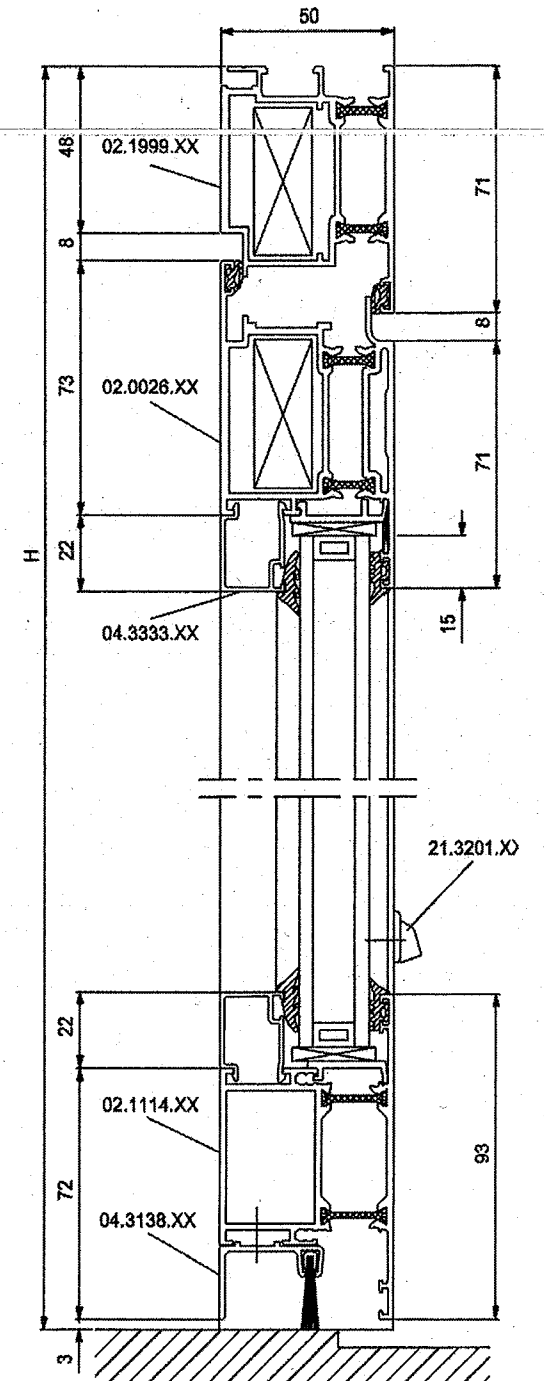

DOCUMENT GAMMISTE PORTE BATTANTE SANS SEUIL  
OUVERTURE VERS L'INTERIEUR 1 ET 2 VANTAUX  
Nomenclature et débits

COUPES PROFILES DE LA PORTE :

PROFILES / PROFILES

REFERENCE REFERENCE	DESIGNATION DESCRIPTION	PROFILE PROFILE	COUPE SECTION	1 VANTAIL / 1 VENT		2 VANTAUX / 2 VENTS	
				Q	D / S	Q	D / S
02.0014.XX	OUVRANT PORTE-T** VENT DOOR**			-	-	1	H - 59
02.0026.XX	OUVRANT PORTE Z** VENT Z**			1	H - 59	1	H - 59
				1	H - 59	2	H - 59
				1	L - 112	1	L1-48.5
				1	L - 112	1	L2-48.5
02.1114.XX	TRAVERSE 93mm TRANSOM 93mm			1	L - 258	2	L1 - 194,5 L2 - 194,5
02.1999.XX	DORMANT PORTE OUTER FRAME DOOR			1	H	1	H
				1	H	1	H
				1	L	1	L
04.3138.XX	PROFILE SUPPORT BROSE SUR T BOTTOM DOOR RAIL			1	L - 258 H	2	L1 - 194,5 L2 - 194,5
04.3333.XX	PARCLOSE DE 18,5mm GLAZING BEAD VENT 18,5mm			2	L - 258	2	L1 - 194,5
				2	H - 248	2	L2 - 194,5
				4	H - 248	4	H - 248

02.0014. XX

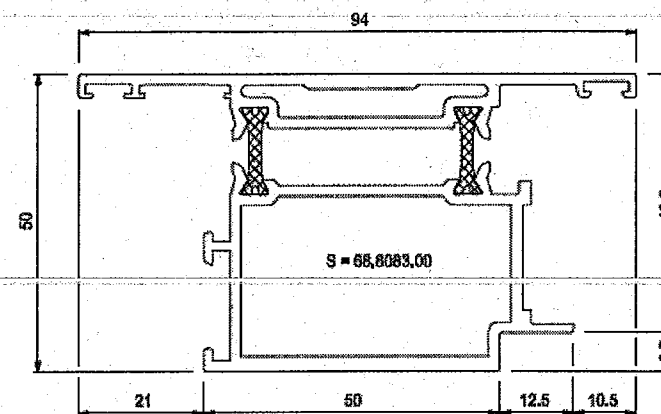

02.1969.XX

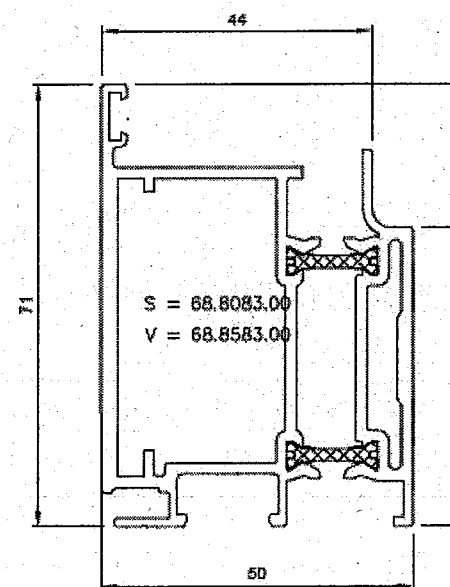

02.1999.XX

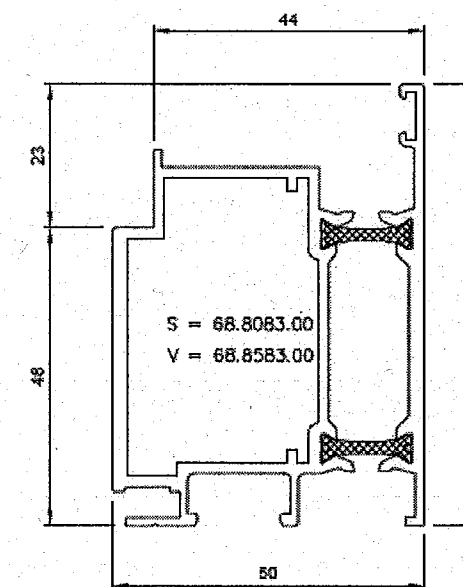

02.1114.XX

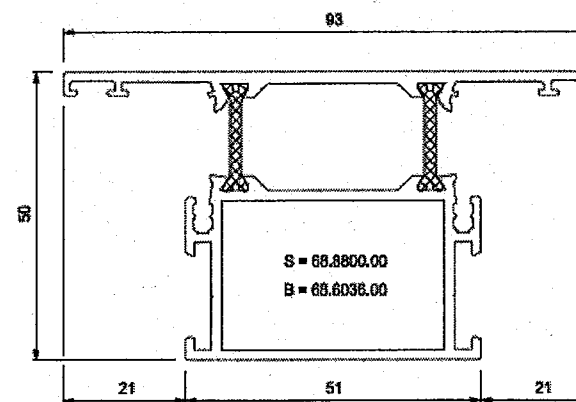

02.0026. XX

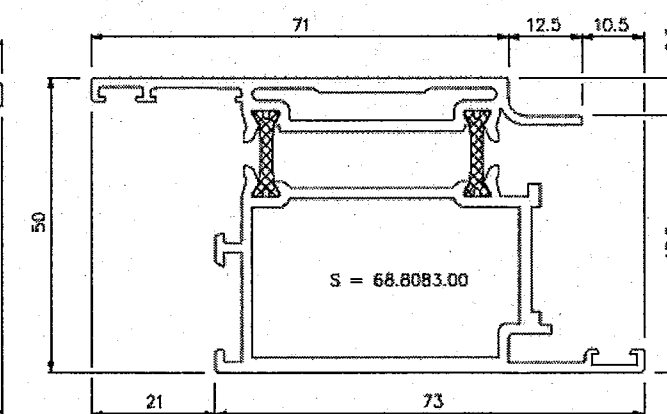

**IMPORTANT :** Dans le cas d'une ouverture vers l'extérieur, le profilé 02.0014.XX est remplacé par le 02.0026.XX, les profilés 02.0026.XX par des 02.0014.XX et les 02.1999.XX par des 02.1969.XX

COUPES HORIZONTALE ET VERTICALE DU CHASSIS FIXE REP. D

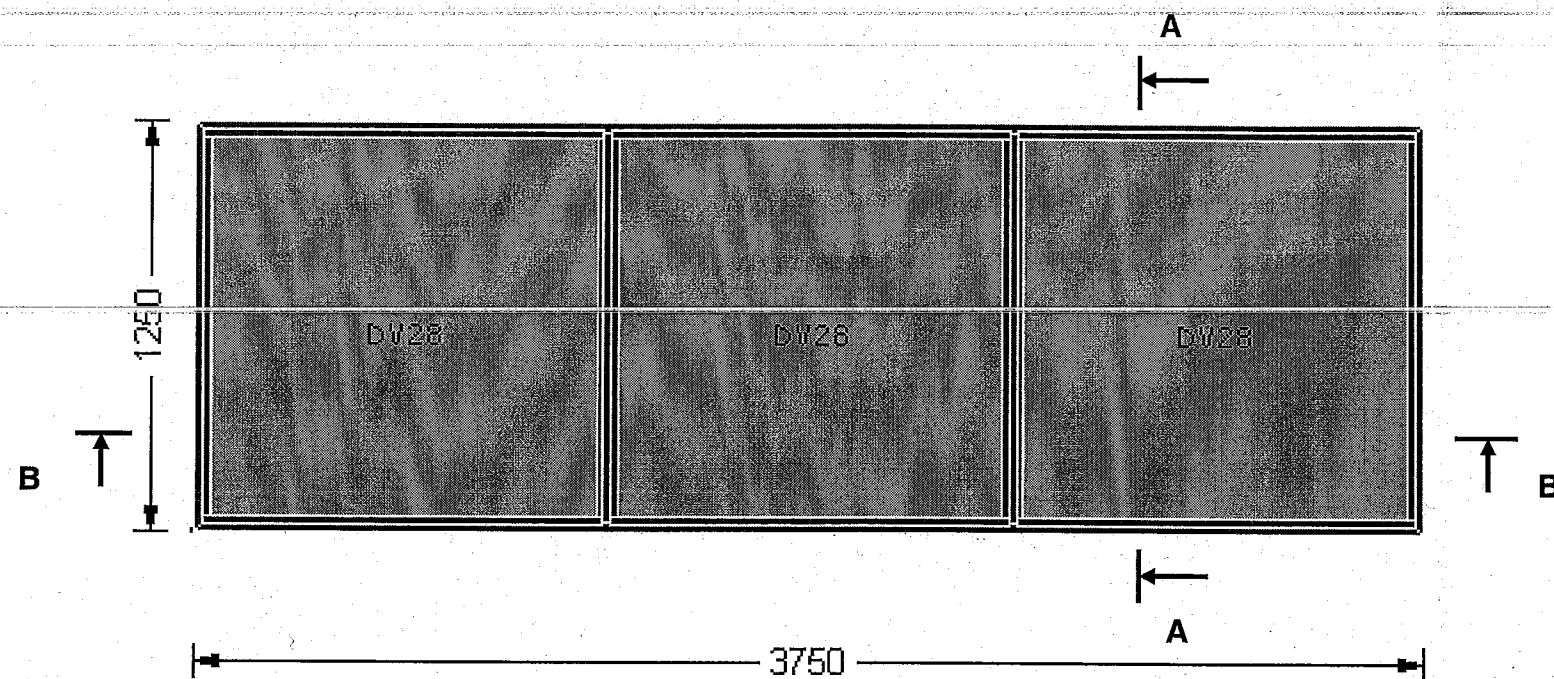

COUPE HORIZONTALE B-B

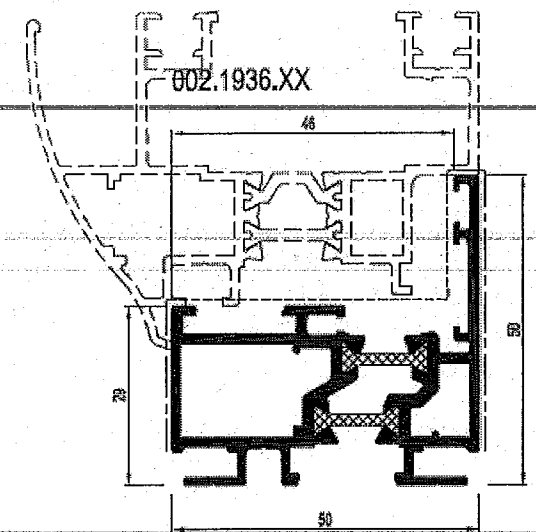

COUPE VERTICALE A-A

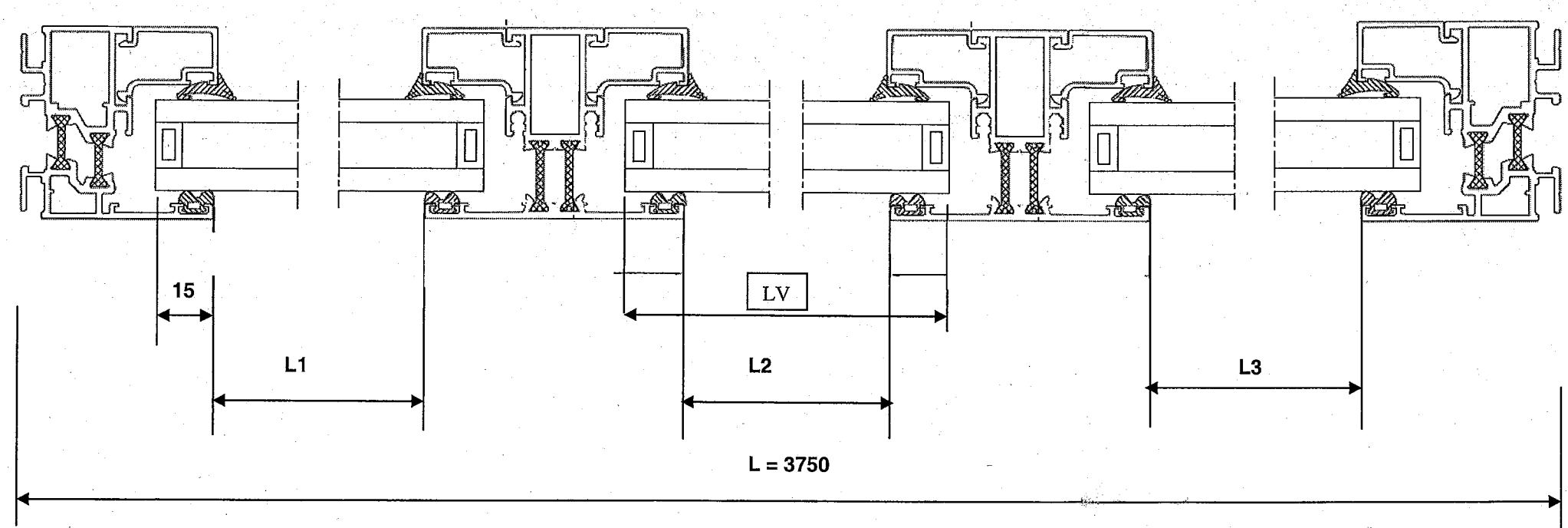
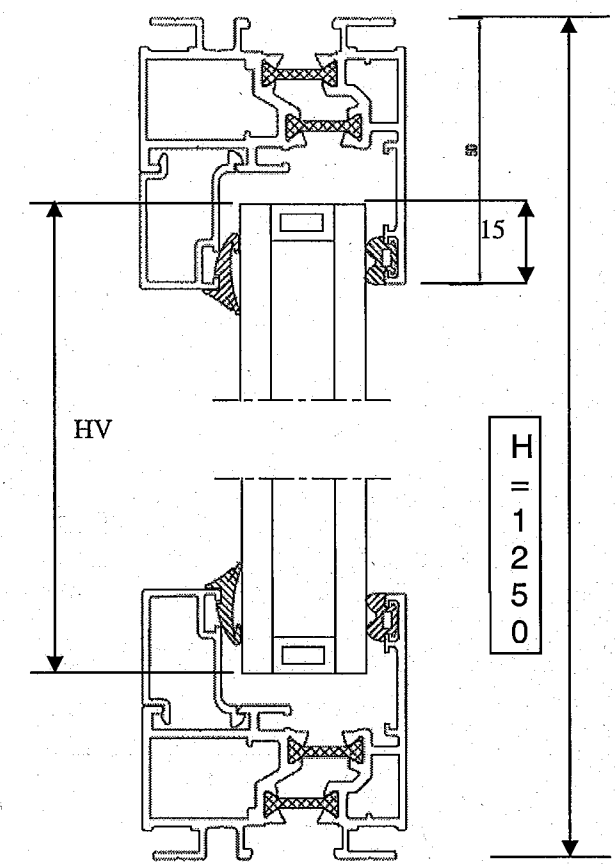
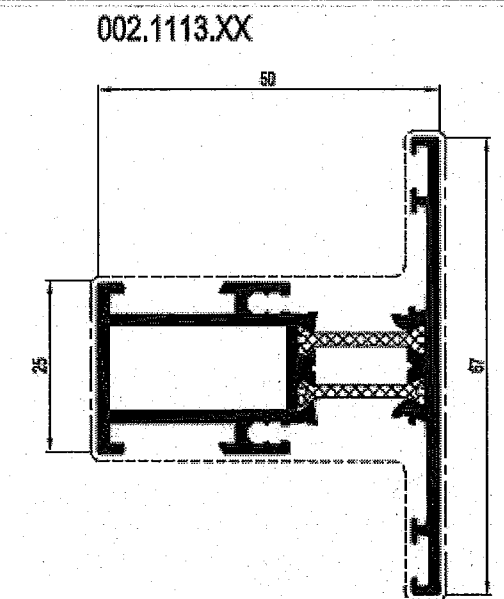

# PLANCHE DE MONTAGE EQUERRES ET BLOCS D'ASSEMBLAGE :

## ASSEMBLAGE PAR SERTISSAGE ASSEMBLY BY CRIMPING

068.7572.00    068.8180.00

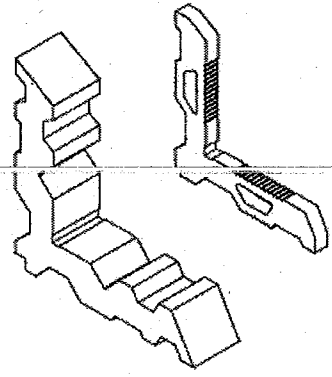

NOTA (CF norme NF P 24-301)  
 Pour l'assemblage  
 ① . Etancher le bloc par application de mastic élastomère 1ère catégorie dans les tubulures;  
 ② . Etancher la coupe au mastic fluide (En zone littoral appliquer du produit anti-corrosion référence 086.9608.- -)

NOTE (CF standard NF P 24-301)  
 For assembly  
 ① . Seal the block by means of sealing agent 1st cat. in outer frame  
 ② . Seal the saw cut by means of liquid sealing agent. (In littoral zone, applying a corrosion preventing agent ref : 086.9608.- -)

## ASSEMBLAGE PAR VISSAGE ASSEMBLY BY SCREWING

068.8593.00    068.8180.00

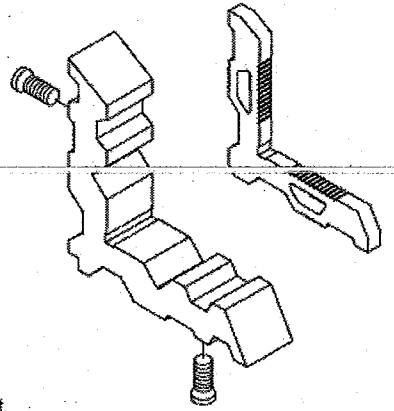

## ASSEMBLAGE PAR JONCTION-T ASSEMBLY BY T-BRACKET

CORRESPONDANCE	
PROFILES	JUNCTION - T/ T-BRACKET
002.1900.XX	
002.1910.XX	068.6855.00
002.1911.XX	
002.1113.XX	068.8750.00
002.1120.XX	068.8751.00
002.1114.XX	068.8752.00

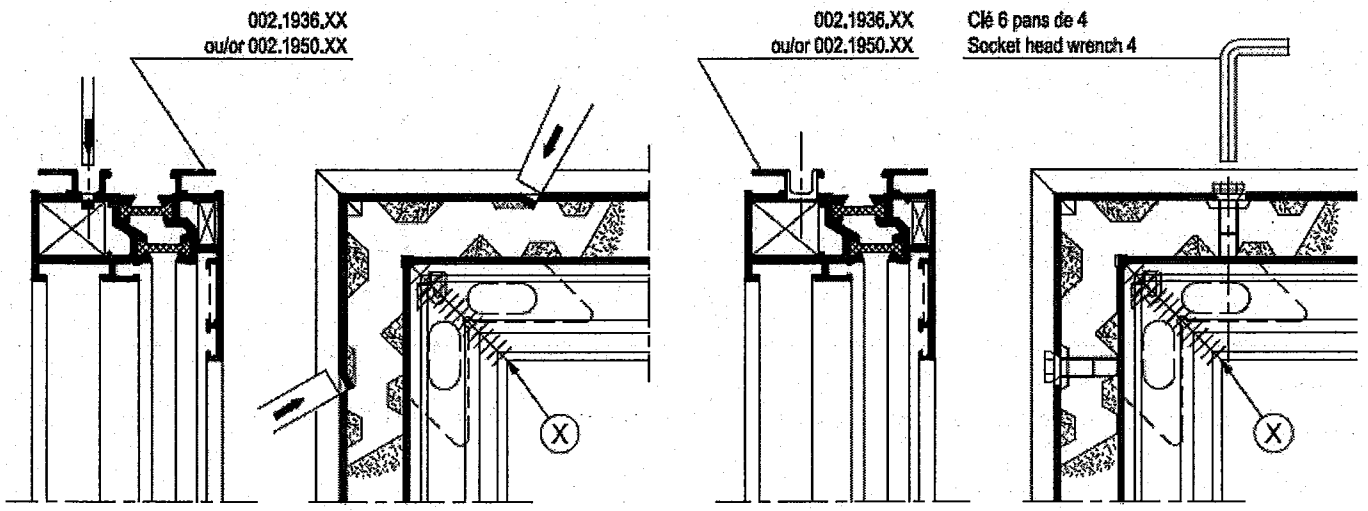
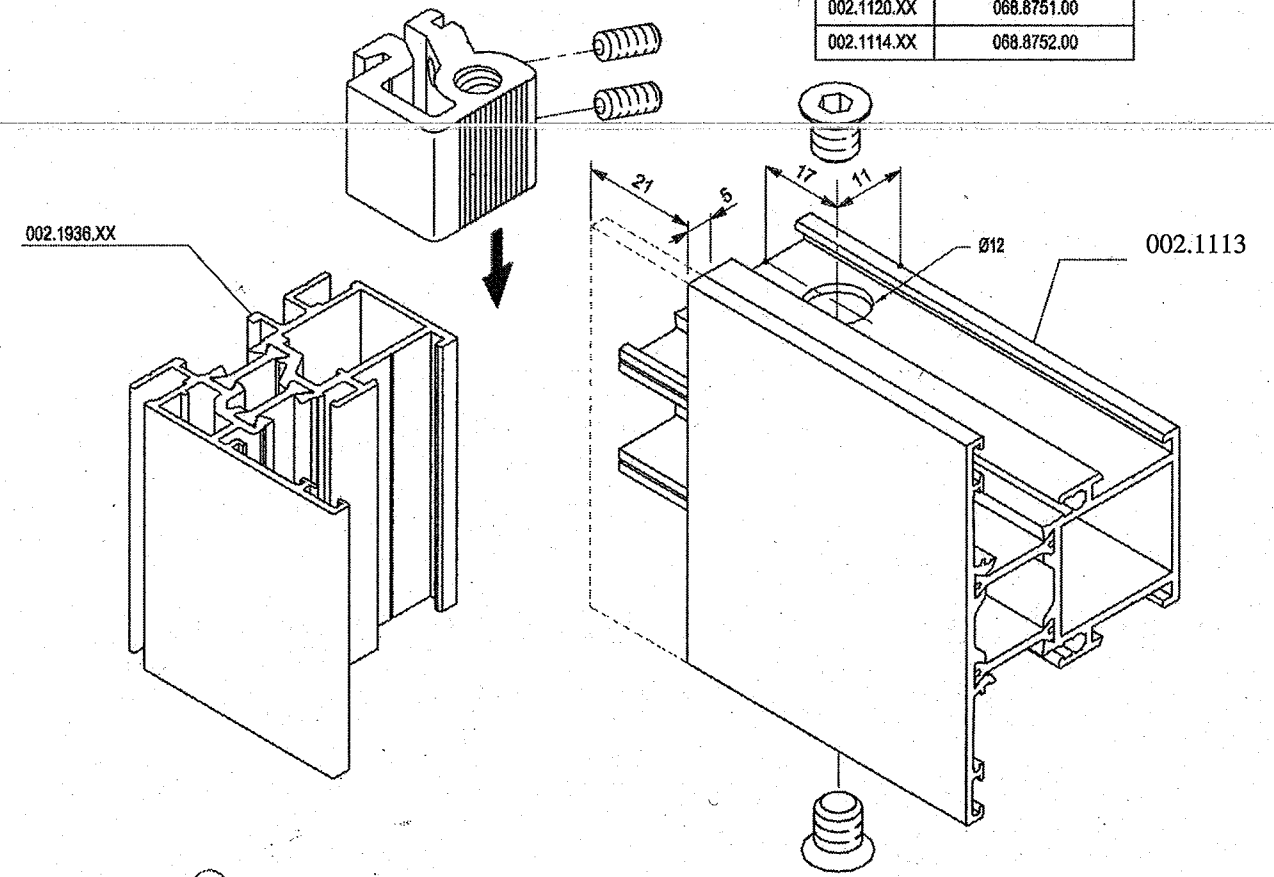

060.8720.- -

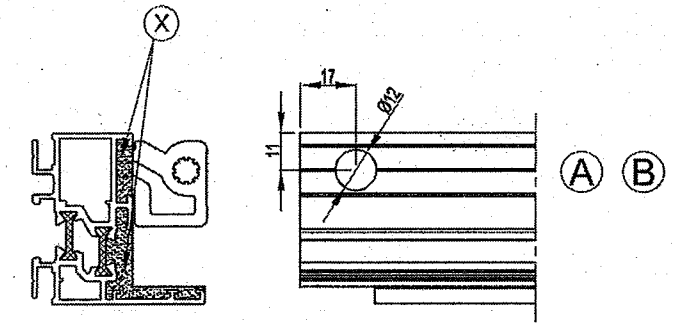
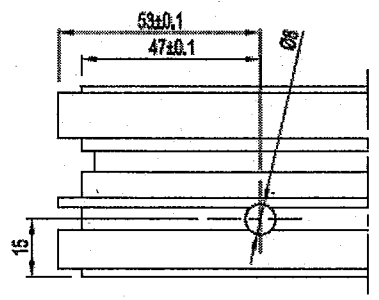
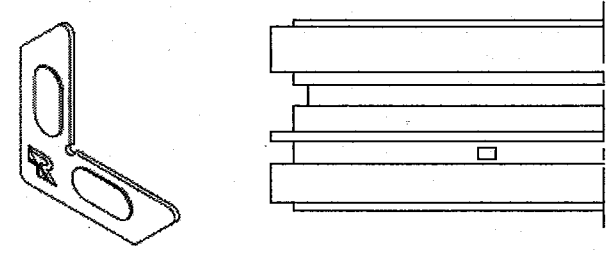

CALIBRE DE PERÇAGE  
BORING JIG    097.0092.00    A

MATRICE GUIDÉE MULTIFONCTIONNELLE  
MULTIFUNCTIONAL PUNCH TOOL    097.C500.00    B

X MATIÈRE D'ÉTANCHEITE  
SEALING AGENT

NOTA (CF norme NF P 24-301)  
 Pour l'assemblage  
 ① . Etancher le bloc par application de mastic élastomère 1ère catégorie dans les tubulures;  
 ② . Etancher la coupe au mastic fluide (En zone littoral appliquer du produit anti-corrosion référence 086.9608.- -)

NOTE (CF standard NF P 24-301)  
 For assembly  
 ① . Seal the block by means of sealing agent 1st cat. in outer frame  
 ② . Seal the saw cut by means of liquid sealing agent. (In littoral zone, applying a corrosion preventing agent ref : 086.9608.- -)



Butée de réglage de la profondeur

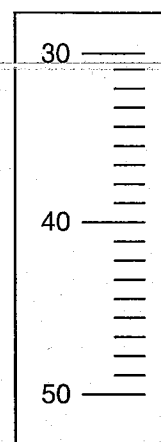
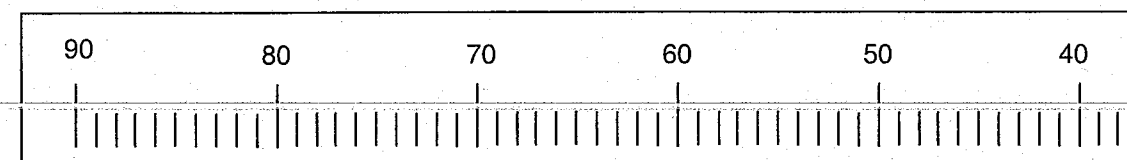
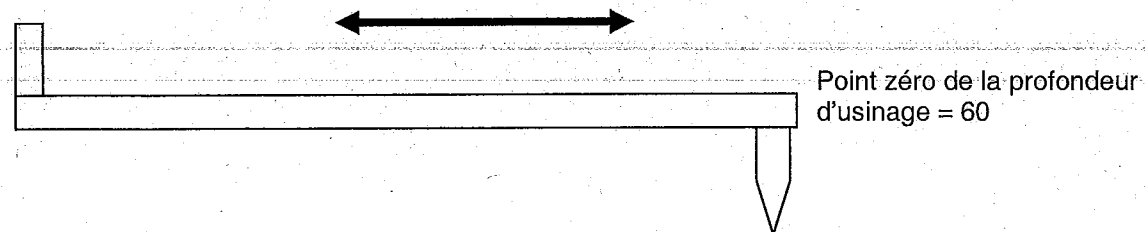

Point zéro de la hauteur d'usinage = 40

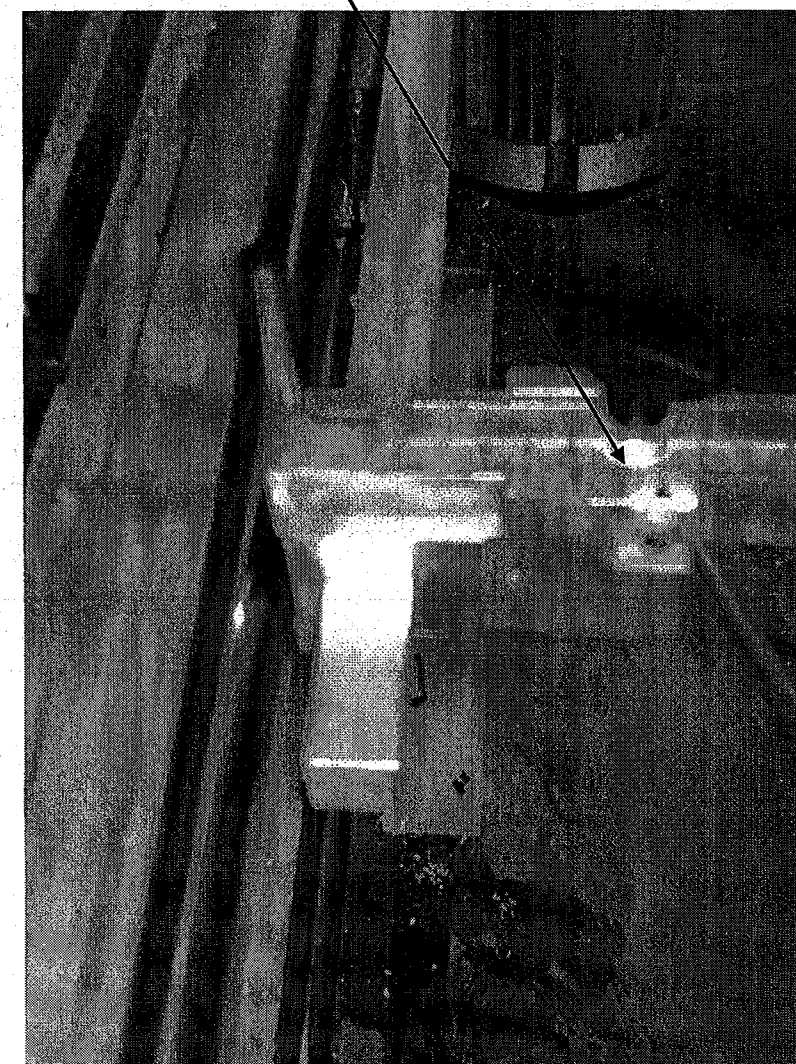
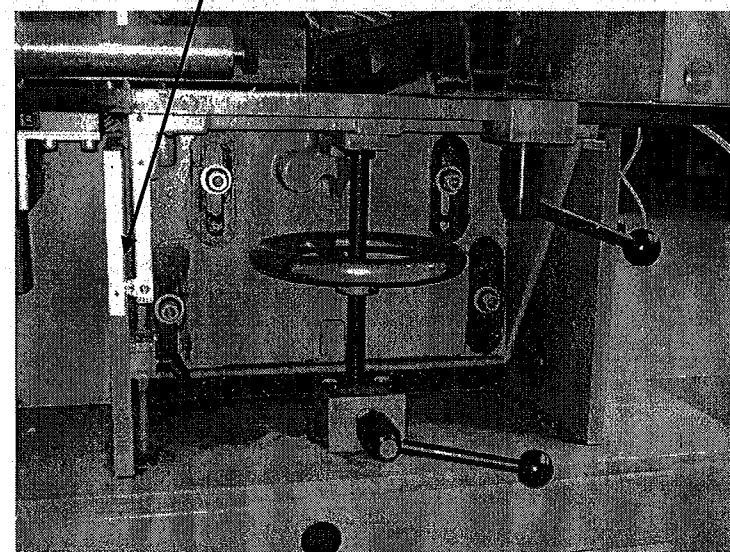
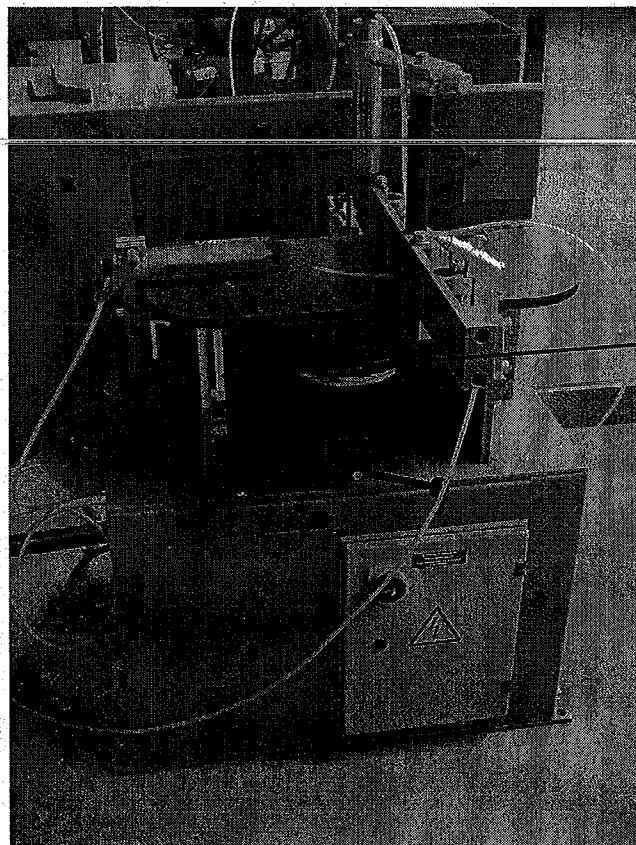

# FICHE TECHNIQUE FRAISEUSE EN BOUT ET SYMBOLISATION ISOSTATISME

Elévation

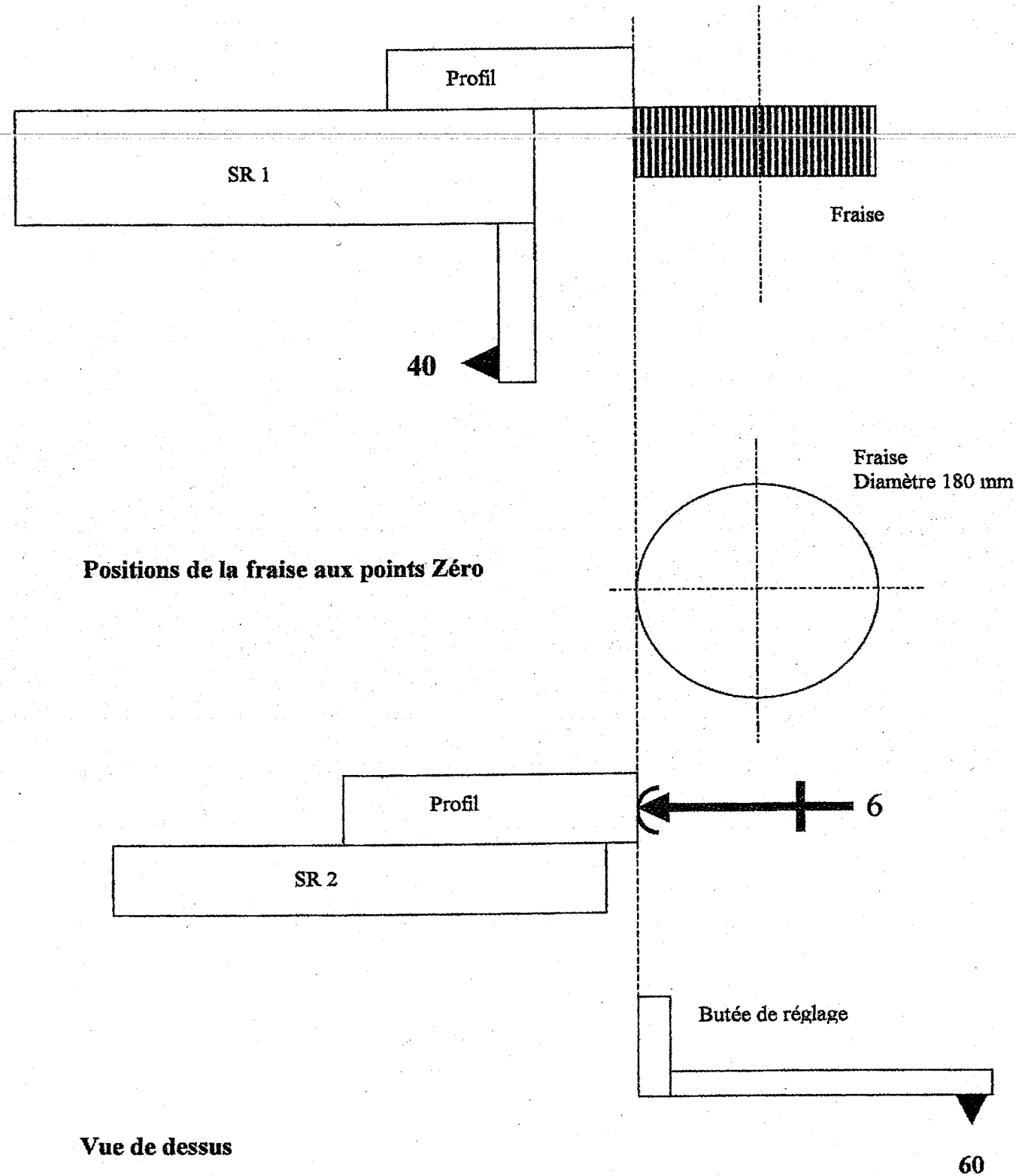



Vue de dessus

Symbolisation d'isostatisme		
Symbolisation des éléments d'appui et de maintien		
	Profil	Projection
Appui fixe		
Centrage fixe		
Système à serrage		
Symbolisation de la nature de la surface de contact de la pièce		
Appui sur une surface brute :		
Appui sur une surface usinée :		
Symboles indiquant la nature du contact avec la surface la pièce		
Contact ponctuel :		Symbole :
Contact surfacique :		Symbole :

# FICHE DE DEBIT MUR-RIDEAU REPERE P

## Profilés

0340536.59 7016		PROFILE DE RECOUVREMENT 15MM RAL 60µ BRILL CAT 2 (Gris anthracite)				
Qté	Position	L. scie	Angle 1	Angle 2	Référence	
1x	*	1172,8mm	86,7°	93,3°	GIRODREP P*00001*1	
11x	-	1168,0mm	90,0°	90,0°	GIRODREP P*00001*1	
2x	*	1147,8mm	86,7°	93,3°	GIRODREP P*00001*1	
22x	-	1143,0mm	90,0°	90,0°	GIRODREP P*00001*1	

0340537.59 7016		PROFILE DE RECOUVREMENT 18MM RAL 60µ BRILL CAT 2 (Gris anthracite)				
Qté	Position	L. scie	Angle 1	Angle 2	Référence	
1x		5060,0mm	90,0°	86,7°	GIRODREP P*00001*1	
1x		4991,4mm	90,0°	93,3°	GIRODREP P*00001*1	
1x		4921,4mm	90,0°	93,3°	GIRODREP P*00001*1	
1x		4852,9mm	90,0°	93,3°	GIRODREP P*00001*1	

0340556.00		SERREUR VERTICAL BRUT				
Qté	Position	L. scie	Angle 1	Angle 2	Référence	
1x		5060,0mm	90,0°	86,7°	GIRODREP P*00001*1	
1x		4991,4mm	90,0°	93,3°	GIRODREP P*00001*1	
1x		4921,4mm	90,0°	93,3°	GIRODREP P*00001*1	
1x		4852,7mm	90,0°	93,3°	GIRODREP P*00001*1	

0341507.59 7016		MENEAU 184MM RAL 60µ BRILL CAT 2 (Gris anthracite)				
Qté	Position	L. scie	Angle 1	Angle 2	Référence	
1x		5060,0mm	86,7°	90,0°	GIRODREP P*00001*1	
1x		4991,4mm	90,0°	93,3°	GIRODREP P*00001*1	
1x		4921,4mm	90,0°	93,3°	GIRODREP P*00001*1	
1x		4852,9mm	90,0°	93,3°	GIRODREP P*00001*1	

0342522.59 7016		TRAVERSE 67.2MM RAL 60µ BRILL CAT 2 (Gris anthracite)				
Qté	Position	L. scie	Angle 1	Angle 2	Référence	
1x	*	1204,8mm	93,3°	86,7°	GIRODREP P*00001*1	
11x	-	1200,0mm	90,0°	90,0°	GIRODREP P*00001*1	
2x	*	1179,8mm	93,3°	86,7°	GIRODREP P*00001*1	
22x	-	1175,0mm	90,0°	90,0°	GIRODREP P*00001*1	

0342535.00		SERREUR H BRUT				
Qté	Position	L. scie	Angle 1	Angle 2	Référence	
1x	*	1170,8mm	86,7°	93,3°	GIRODREP P*00001*1	
11x	-	1166,0mm	90,0°	90,0°	GIRODREP P*00001*1	
2x	*	1145,8mm	86,7°	93,3°	GIRODREP P*00001*1	
22x	-	1141,0mm	90,0°	90,0°	GIRODREP P*00001*1	



# EXEMPLE DE MISE EN BARRE :

## DORMANT 021936

### Pièces à réaliser (débit):

- 3 pièces de 2900 mm
- 2 pièces de 2700 mm
- 8 pièces de 2445 mm
- 2 pièces de 1050 mm
- 4 pièces de 941 mm
- 2 pièces de 907 mm

Longueur des barres : 6500 mm Contraintes de débit sur tronçonneuse deux têtes : <ul style="list-style-type: none"><li>- Affranchissement de la barre : 30 mm</li><li>- Perte entre coupes : 10 mm</li><li>- Perte par coupe : 10 mm</li></ul>
---

	DEBIT	RESTE
BARRE 1	1*2900 + 1*2445 + 1*1050	5 mm
BARRE 2	1*2900 + 1*2445 + 1*1050	5 mm
BARRE 3	1*2900 + 1*2445 + 1*941	114 mm
BARRE 4	2*2700 + 1*941	59 mm
BARRE 5	1*2445 + 2*941 + 2*907	199 mm
BARRE 6	2*2445	1540 mm
BARRE 7	2*2445	1540 mm
BARRE 8		

### BON DE COMMANDE

REFERENCE	DESIGNATION	NOMBRE DE BARRES
021936	DORMANT	7 barres